

# CHAPTER 44

## HIGH WIND ZONES

### SECTION 4401 GENERAL

The provisions of this chapter shall be applicable to buildings constructed in high wind zones as noted by the text. These provisions shall be in addition to or in lieu of the requirements for the code requirements of Chapters 1 through 8.

**4401.1 Alternate construction.** In lieu of specific code requirements for structures in the 110, 120 and 130 miles per hour wind zones, compliance with SBCCI SSTD 10-99 Standard for Hurricane Resistant Construction or AFPA WFCM-01 *Wood Frame Construction Manual for One- and Two-Family Dwellings* is acceptable.

### SECTION 4402

**TABLE 4402(a)**  
**DESIGN PRESSURES FOR DOORS AND WINDOWS<sup>1,2,3,4</sup>**  
**POSITIVE AND NEGATIVE IN PSF**

Velocity (mph)	Mean Roof Height (ft)		
	15	25	35
110	25	29	32
120	31	35	39
130	37	43	47

For SI: 1 foot = 304.8 mm, 1 mile per hour = 0.44 m/s.

- Alternate pressures may be determined by using North Carolina State Building Code, ASCE-7-02 or the 2006 *International Building Code*.
- If window or door is more than 4 feet from a corner, the pressure from this table shall be permitted to be multiplied by 0.87. This adjustment does not apply to garage doors.
- For windows or doors in structures with a roof slope of 10 degrees (2:12) or less from the horizontal, the pressure from this table may be multiplied by 0.90.
- Design pressure ratings based on the standards listed in Section R613 are adequate documentation of capacity to resist pressures from the table.

**TABLE 4402(b)**  
**DESIGN PRESSURES IN PSF GARAGE DOORS**

Velocity (mph)	Mean Roof Height (ft)		
	15	25	35
110	20	23	26
120	25	29	32
130	30	35	39

For SI: 1 foot = 304.8 mm, 1 mile per hour = 0.44 m/s.

- The pressures in this table are for garage doors at least 9 feet by 7 feet and at least 2 feet from the corner.
- Alternate design pressures may be determined by using the North Carolina State Building Code, ASCE 7-02, DASMA Technical Data Sheet 155h (for garage doors), or the 2006 *International Building Code*.
- For doors in a structure with a roof slope of 10 degrees (2:12) or less from the horizontal the pressures from this table may be multiplied by 0.90.
- Design pressure ratings based on tests done according to ASTM E330 are adequate documentation.
- Garage doors on the ground level of a structure in a flood zone do not have to meet the above design pressures provided all of the following conditions are met:

- Structure is anchored to the girders and top of the piling to resist the forces given in Chapter 44.
- The garage door occurs below the top of the piling.
- Provide openings at the garage level that comply with either of the following options:
  - Design all exterior walls at the garage level to break away at 20 psf or less; or
  - Provide openings (in walls at the garage level without the garage level without the garage door) equal to at least 20 percent of the total wall area from the ground to the roof.

### SECTION 4403 FOOTINGS

**4403.1 Foundation wall footings.** Foundation wall footings in the 120 (53 m/s) and 130 mph (57 m/s) wind zones shall be a minimum of 8 inches by 24 inches (203 mm by 610 mm) for houses 2 1/2 stories and less. The footing for a three story building shall be 10 inches by 24 inches (254 mm by 610 mm). Footings shall be reinforced with three No. 4 (or two No. 5 bars) at 3 inches (76 mm) above the bottom of the footing. The bars shall be continuous or lapped 25 inches (633 mm) at all splices.

#### 4403.2 Pier and curtain wall footings.

**4403.2.1 Enlarged footings at piers.** The curtain wall footing must meet the minimum projection requirements in Figure R403.1(1) and footing dimensions for the pier footings shall comply with Table 4403.2.1.

**TABLE 4403.2.1**  
**FOOTINGS TO RESIST UPLIFT FROM PIERS IN 120 AND 130 MPH WIND ZONES SUPPORTING GIRDERS IN EXTERIOR WALLS**

Velocity (mph)	Footing Size Girder Span		
	4'-0"	6'-0"	8'-0"
120	2'-0" x 2'-0" x 10"	2'-4" x 2'-4" x 10"	2'-8" x 2'-8" x 10"
130	3'-0" x 3'-0" x 10"	3'-4" x 3'-4" x 12"	3'-8" x 3'-8" x 12"

For SI: 1 inch = 25.4 mm, 1 foot = 304.8 mm, 1 mile per hour = 0.44 m/s.

Note: See Table 403.1(a) for 110 mph.

**4403.2.2 Continuous width footings.** Uniform continuous width footings for pier and curtain wall foundations shall be a minimum of 8 inches (208 mm) thick and 24 inches (610 mm) wide. Footings shall be reinforced with No. 4 bars (or two No. 5 bars) at 3 inches above the bottom of the footing. The bars shall be continuous or lapped 25 inches (633 mm) at all splices.

**4403.3 Footing dowels.** All footings shall have dowels to match reinforcing in the foundation wall or pier above (see Sections 4404.1.1 and 4404.3). Dowels shall have a standard hook embedded in the footing at least 25 inches (633 mm) for a No. 5 reinforcing bar.

**SECTION 4404  
WALL AND FOUNDATION ANCHORAGE**

**4404.1 Anchorage.** Exterior walls of structures in the 120 and 130 mph (57 m/s) wind zones shall be anchored to the footing to resist either the forces specified in Section 4408.2 or the prescriptive requirements of this Section. Exterior walls of structures in the 110 mph (48 m/s) wind zone shall be anchored to the foundation wall, pier/curtain wall, or slab on grade with 1/2-inch anchor bolts 4 feet o.c. extended 15 inches (381 mm) into masonry and 7 inches (178 mm) into concrete and are exempt from the requirements of this section.

**TABLE 4404.1(a)  
STRUCTURAL ANCHORAGE<sup>1</sup>**

Wind Speed (mph)	120	130
Maximum spacing (inches)	21	18

For SI: 1 inch = 25.4 mm, 1 foot = 304.8 mm, 1 mile per hour = 0.44 m/s.  
1. Required spacing of 1/2-inch anchor bolts where a bond beam is required and for slab on grade with a single sole plate (see Figure 4403.1(1) for 110mph or less).

**4404.1.1 Exterior foundation walls.** Vertical reinforcement shall be installed not more than 2 feet (610 mm) from each corner at intervals not to exceed Table 4404.1.1 with all reinforced cells grouted and shall either terminate in a bond beam or connect to the wall above.

**TABLE 4404.1.1  
WALL REINFORCEMENT OR CONTINUOUS ANCHORAGE**

Bar/Bolt Size (inches)	5/8	1/2	3/8
Maximum Spacing (inches)	96	72	42

For SI: 1 inch = 25.4 mm, 1 foot = 304.8 mm, 1 mile per hour = 0.44 m/s.  
1. Applies to 120 and 130 mph wind zones.  
2. Continuous anchorage from footing to girder or wall framing.  
3. Applies to footing dowel bars, vertical reinforcement, and anchor bolts.  
4. Spacing may exceed the tabulated values by up to 8 inches provided the total number of required bars is installed.

**4404.1.2** An 8-inch by 8-inch (203 mm by 203 mm) concrete or CMU bond beam with one No. 5 bar shall be used at the floor level. The bar shall be continuous or lapped 25 inches (635 mm) at all splices.

**Exception:** The bond beam may be eliminated where the uplift connectors are continuous from the footing to the exterior wall framing and the rim band is continuous (doubled or spliced).

**4404.2 Sill Plates.** A minimum 2-inch by 6-inch (51 mm by 156 mm) sill plate shall be installed.

**Exception:** Where the uplift connectors are continuous from the footing to the exterior wall framing.

**4404.2.1** Sill plates shall be anchored with 1/2-inch anchor bolts with 2-inch by 2-inch by 1/8-inch washers at intervals not to exceed Table 4404.1(a). Where the vertical reinforcement bars/bolts terminate at the sill plate with a connector

capable of developing the bar/bolt capacity, approved strap anchors from the sill plate to the wall framing shall be installed (Note: Cable clamps have no rated capacity when used with reinforcing steel or bolts).

**Exception:** Where the uplift connectors are continuous from the footing to the exterior wall framing, the spacing of the continuous anchorage may be increased per Table 4404.1.1.

**4404.3 Exterior foundation piers.** Vertical reinforcement shall be installed not more than 2 feet (51 mm) from each corner at intervals not to exceed Table 4404.1.1 with all reinforced cells grouted and shall connect to all sill plates, to the exterior girder, or to the wall above [see Figures 4404.3(a) through 4404.3(d)].

**4404.3.1** Where the vertical reinforcement bars terminate at the sill plate, a minimum 2-inch by 6-inch (51 mm by 152 mm) sill plate and approved strap anchors from the sill plate to the wall framing shall be installed.

**4404.3.2** Two No. 4 footing dowel bars shall be embedded into the footing and grouted to the top of each pier. If the vertical reinforcement bars are placed inside the piers (not between the pier/curtain wall), then one footing dowel bar may be omitted from each pier.

**4404.4 Exterior concrete slab-on-grade footings.** Vertical reinforcement shall be installed at intervals not to exceed Table 4404.1.1 and shall terminate in a double sole plate.

**Exception:** Vertical reinforcement (anchorage) shall be installed at intervals not to exceed Table 4404.1(a) where the bars terminate in a single sole plate. Approved strap anchors shall be installed from the single sole plate to the wall.

**SECTION 4405  
WALL CONSTRUCTION**

**4405.1 Construction.** Exterior walls of wood frame construction shall be in accordance with Figures R602.3(1) and R602.3(2). Components of exterior walls shall be fastened in accordance with Table R602.3(1). Walls of wood frame construction shall be designed and constructed in accordance with Chapter 43 of NFPA *National Design Specifications for Wood Construction*.

Exterior walls subject to wind pressures of 110 mph (48 m/s) or greater as established in Table R301.2(1) shall be designed in accordance with accepted engineering practice [such as Tables 4405(a) and 4405(b)].

In bearing walls, studs which are not more than 10 feet (3048 mm) in length shall be spaced not more than is specified in Tables 4405(a) and 4405(b) for the corresponding stud size.

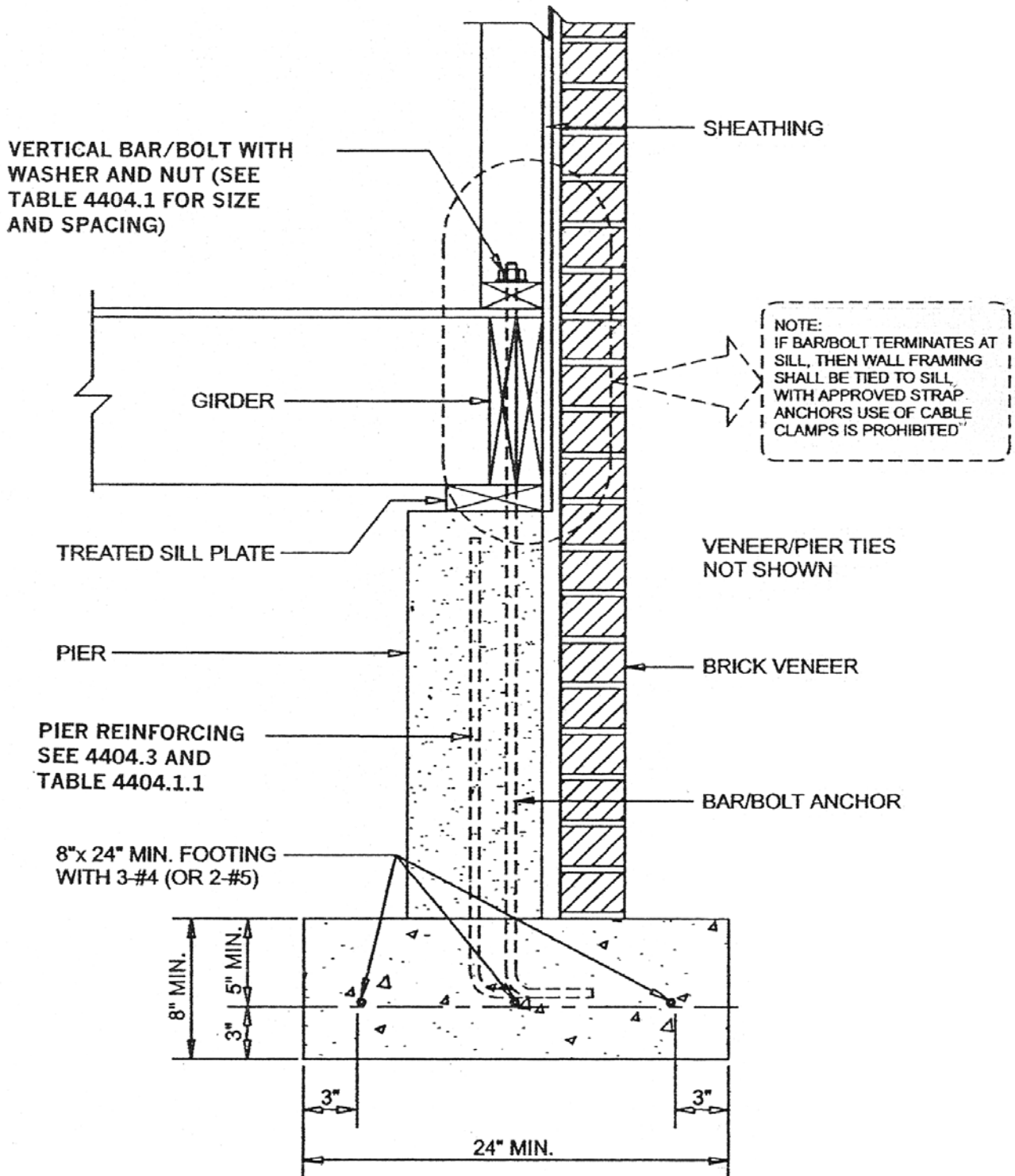

For SI: 1 inch = 25.4 mm.

FIGURE 4404.3(a)  
CONTINUOUS VENEER PIER/CURTAIN WALL

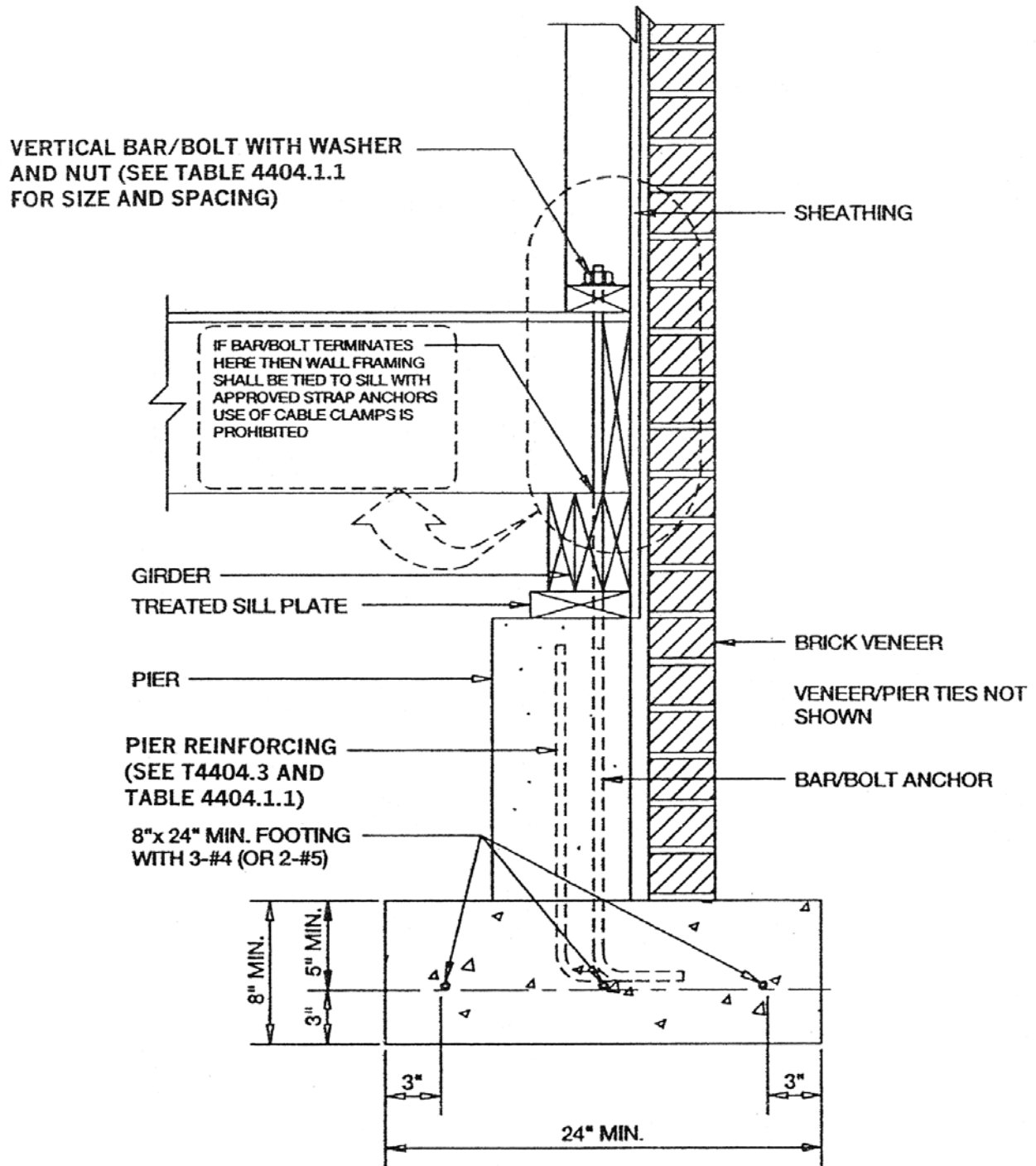

For SI: 1 inch = 25.4 mm.

FIGURE 4404.3(b)  
CONTINUOUS VENEER PIER/CURTAIN WALL

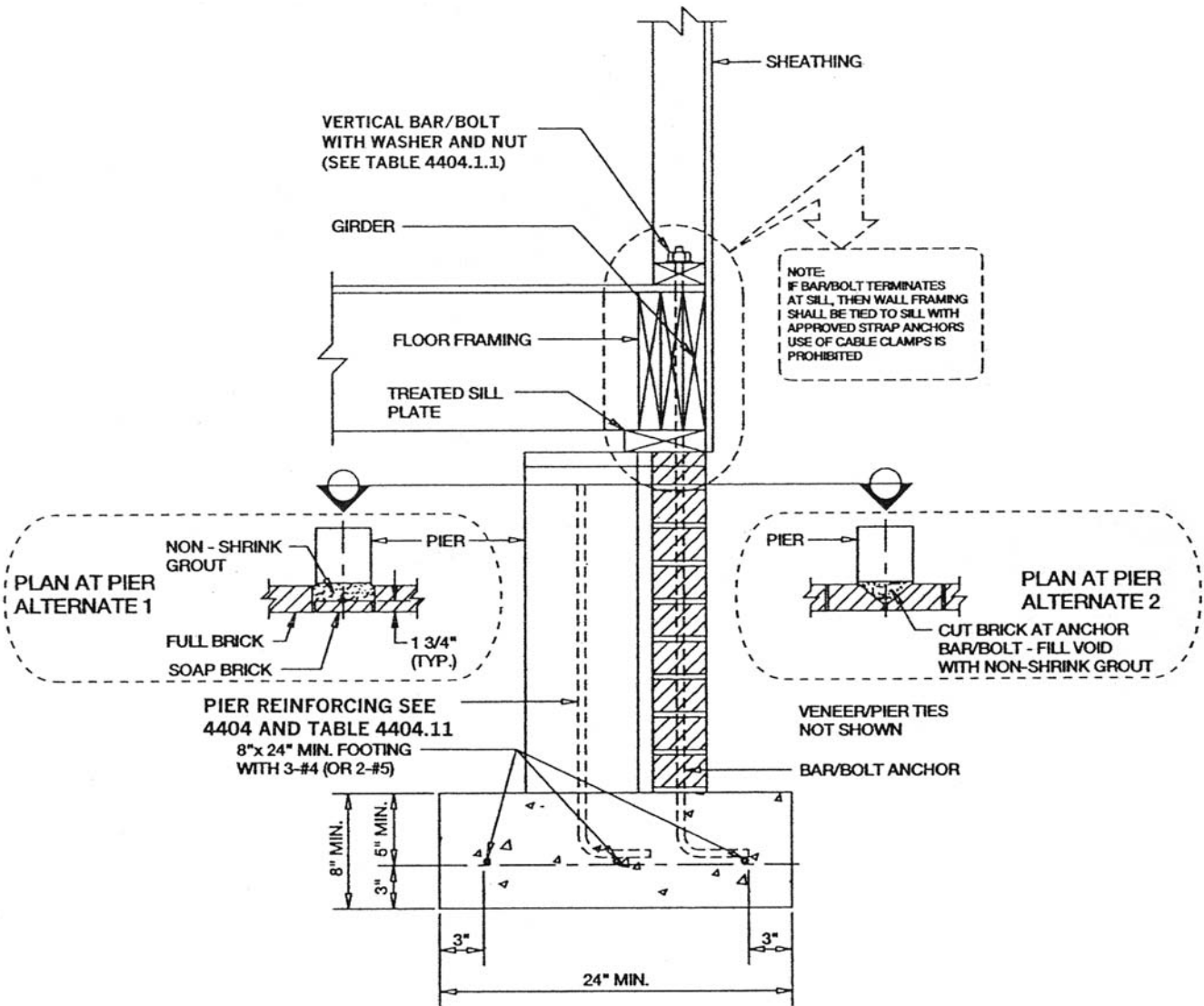

For SI: 1 inch = 25.4 mm.

FIGURE 4404.3(c)  
VENEER SHIRT WALL PIER/CURTAIN WALL

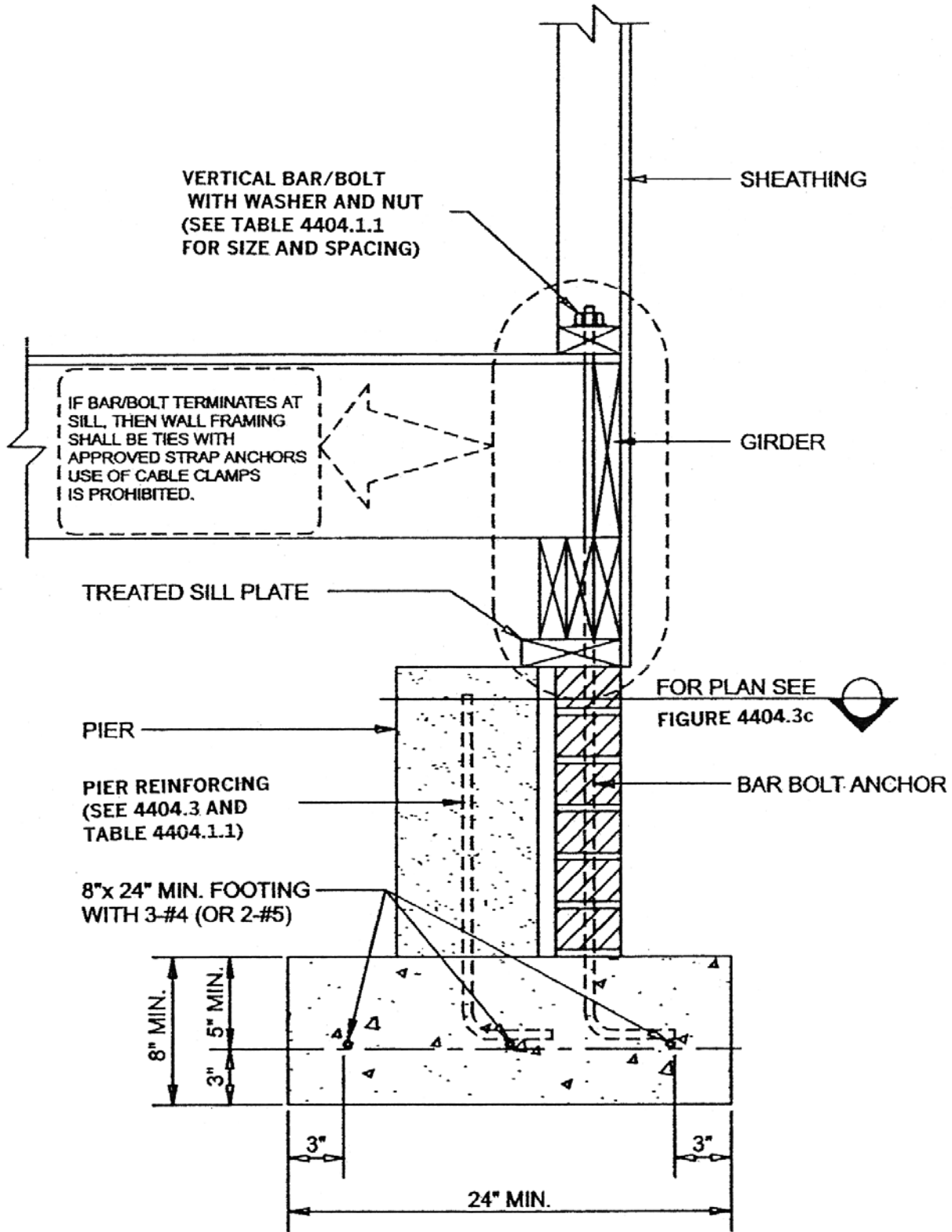

For SI: 1 inch = 25.4 mm.

FIGURE 4404.3(d)  
VENEER SHIRT WALL PIER/CURTAIN WALL

**TABLE 4405(a)**  
**STUDS IN 110, 120 AND 130 MPH ZONES**

**Requirements for Wood Stud In:**  
**Exterior Walls Supporting One Floor, Roof and Ceiling or Less Exterior Nonloadbearing Walls in Two-story Structure or Less**  
**Interior Walls Supporting One Floor, Roof and Ceiling or Less**

Stud Length	Stud Spacing	110 MPH		110 MPH		120 MPH		130 MPH	
		2x4	2x6	2x4	2x6	2x4	2x6	2x4	2x6
8	16	Species: Spruce Pine Fir (South) Without Structural Sheathing		Species: Spruce Pine Fir (South) With $\frac{3}{8}$ " Wood Structural Sheathing					
		#2	Stud	Stud	Stud	Stud	Stud	#2	Stud
8	24	#2	Stud	#2	Stud	#2	Stud	#2	Stud
10	16	#2	Stud	#2	Stud	#2	Stud	#2	Stud
10	24	Design	#2	Design	#2	Design	#2	Design	#2
—	—	Species: Spruce Pine Fir Without Structural Sheathing		Species: Spruce Pine Fir (South) With $\frac{3}{8}$ " Wood Structural Sheathing					
8	16	Stud	Stud	Stand	Stud	Stud	Stud	#3	Stud
8	24	#2	Stud	#3	Stud	#2	Stud	#2	Stud
10	16	#2	Stud	#2	Stud	#2	Stud	#2	Stud
10	24	Design	Stud	#2	Stud	Design	Stud	Design	Stud
—	—	Species: Southern Pine without Structural Sheathing		Species: Southern Pine with $\frac{3}{8}$ " Wood Structural Sheathing					
8	16	Stud	Stud	Stand	Stud	Stud	Stud	Stud	Stud
8	24	#2	Stud	Stud	Stud	#2	Stud	#2	Stud
10	16	#2	Stud	Stud	Stud	#2	Stud	#2	Stud
10	24	Design	Stud	#2	Stud	#2	Stud	Design	Stud

For SI: 1 inch = 25.4 mm, 1 mile per hour = 0.44 m/s.

Explanation of Table Entries

Design – Studs with this entry shall be in accordance with accepted engineering practice.

#2 - #2 Grade Construction

#3 - #3 Grade

Stud – Stud Grade

Standard – Standard Grade

Utility – Utility Grade

**TABLE 4405(b)**

Exterior Bearing Walls <sup>1,2,3,4,5</sup> First Floor of Three Story						
Wind Zone (mph)	SPE		SP			
	2x4 @ 12" oc Structural Sheathing	3x4 or 2x6 @ 16" oc Structural Sheathing	2x4 @ 12" oc Structural Sheathing	3x4 or 2x6 @ 16" oc Structural Sheathing		
110	#2	Any Grade	Any Grade			
120	#2	Any Grade	#2, #3, Stud			
130	#2	Any Grade	#2, #3, Stud			
Exterior Non-Bearing Walls <sup>1,2,3,4,6</sup> First Floor of Three Story						
Wind Zone (mph)	2x4 @ 12" oc Blocking	2x4 @ 16" oc Blocking	3x4 or 2x6 @ 16" oc Blocking	2x4 @ 12" oc Blocking	2x4 @ 16" oc Blocking	3x4 or 2x6 @ 16" oc Blocking
110	#2, Stud	#2	Any Grade	Any Grade	#2, #3, Stud	Any Grade
120	#2, Stud	NP	Any Grade	#2, #3, Stud	#2, #3 Stud	Any Grade
130	#2	NP	Any Grade	#2, #3, Stud	#2	Any Grade

For SI: 1 inch = 25.4 mm, 1 mile per hour = 0.44 m/s.

1. Any Grade = any grade except standard, utility and economy
2. Corner bracing is REQUIRED where "Blocking" is specified.
3. Two 2x4's @ 16" or 1 - 2x4 @ 8" may be used where 3x4 @ 16" is specified.
4. Refer to 4406 and 4408.4 for sheathing requirements.
5. Bearing stud height is limited to 10 feet (3048 mm).
6. 2x full depth blocking @ mid-height.

**SECTION 4406  
STRUCTURAL BRACING**

**4406.1 Structural bracing in 110 mph wind zone.**

1. When the wall studs are engineered and do not require structural sheathing for one story or top story, brace each corner and at 25 foot intervals with 1 × 4 let-in bracing or 4 feet by 8 feet (1219 mm by 2438 mm) wood structural panels.
2. All other stories—wood structural sheathing panels.
3. See also Section R602.10.

**4406.2 Structural bracing in 120 and 130 mph wind zones.**

All stories – wood structural sheathing panels. Blocking shall be installed if less than 50 percent of the wall length is sheathed. Where blocking is required, all panels shall be fastened at 3 inches (76 mm) o.c. along the edges and 6 inches (152 mm) o.c. at intermediate framing. If a wall is sheathed less than 25 percent of its length, then that wall shall be designed in accordance with accepted engineering practice (see also Section R602.10).

**4406.3 Gable endwalls.** Gable endwalls in the 110, 120, and 130 mph (48 m/s, 53 m/s, 57 m/s) wind zones shall either be supported by lateral bracing at the ceiling or have continuous studs from the floor to the roof. 2 × 4 studs at 16 inches on center are limited to 10 feet in length between supports. Nonbearing 2 × 6 SPF No. 2 studs at 16 inches (406 mm) o.c. with <sup>3</sup>/<sub>4</sub>-inch wood structural panel sheathing are limited to unsupported lengths of 18 feet in 110 mph, 16 feet ( mm) in 120 mph (53 m/s) and 14 feet (4267 mm) in 130 mph (57 m/s) wind

zones. Wood structural panel sheathing shall extend 12 inches (305 mm) beyond construction joints.

**4406.4 Lateral support at ceiling.** Where studs are not continuous, the ceiling must be used to support the endwall. 2 × 4 lateral bracing shall be installed on the top of ceiling joists or truss bottom chords at 8 feet (2438 mm) o.c. and extend 8 feet (2438 mm) inward from the gable endwall [see Figure 4406.7(a)].

**4406.5 Full height studs.** Full height studs may be sized using the bracing at the ceiling to limit the stud length [see Figure 4406.5].

**4406.6 Cathedral endwalls.** Studs shall be continuous from the upper most floor to either the ceiling or the roof.

**4406.7 Overhang at endwalls.** The overhang is limited to 12 inches where a laddered soffit is installed. The overhang may be increased to 24 inches (610 mm) where outlookers are framed over a dropped endwall into the first rafter or truss [see Figure 4406.7(a) and 4406.7(b)]. If the overhang exceeds 24 inches (610 mm), then the overhang shall be designed in accordance with approved engineering practice.

**4406.8 Roof sheathing attachment.** The roof sheathing panel edges shall be blocked and nailed at the end two rafter or truss spaces (see Figure 4406.8).

**Exception:** The panel edges need not be blocked where 2×4 diagonal braces are framed from the top of the endwall to the lateral bracing at the ceiling.

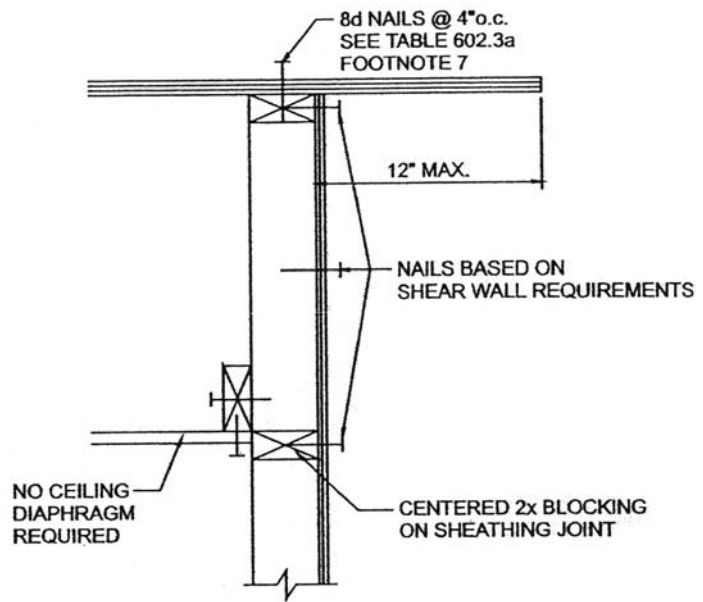
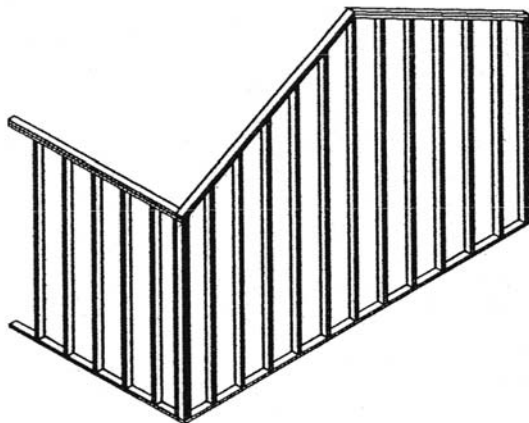

For SI: 1 inch = 25.4 mm.

**FIGURE 4406.5  
GABLE ENDWALL BALLOON FRAMING PREFERRED METHOD**



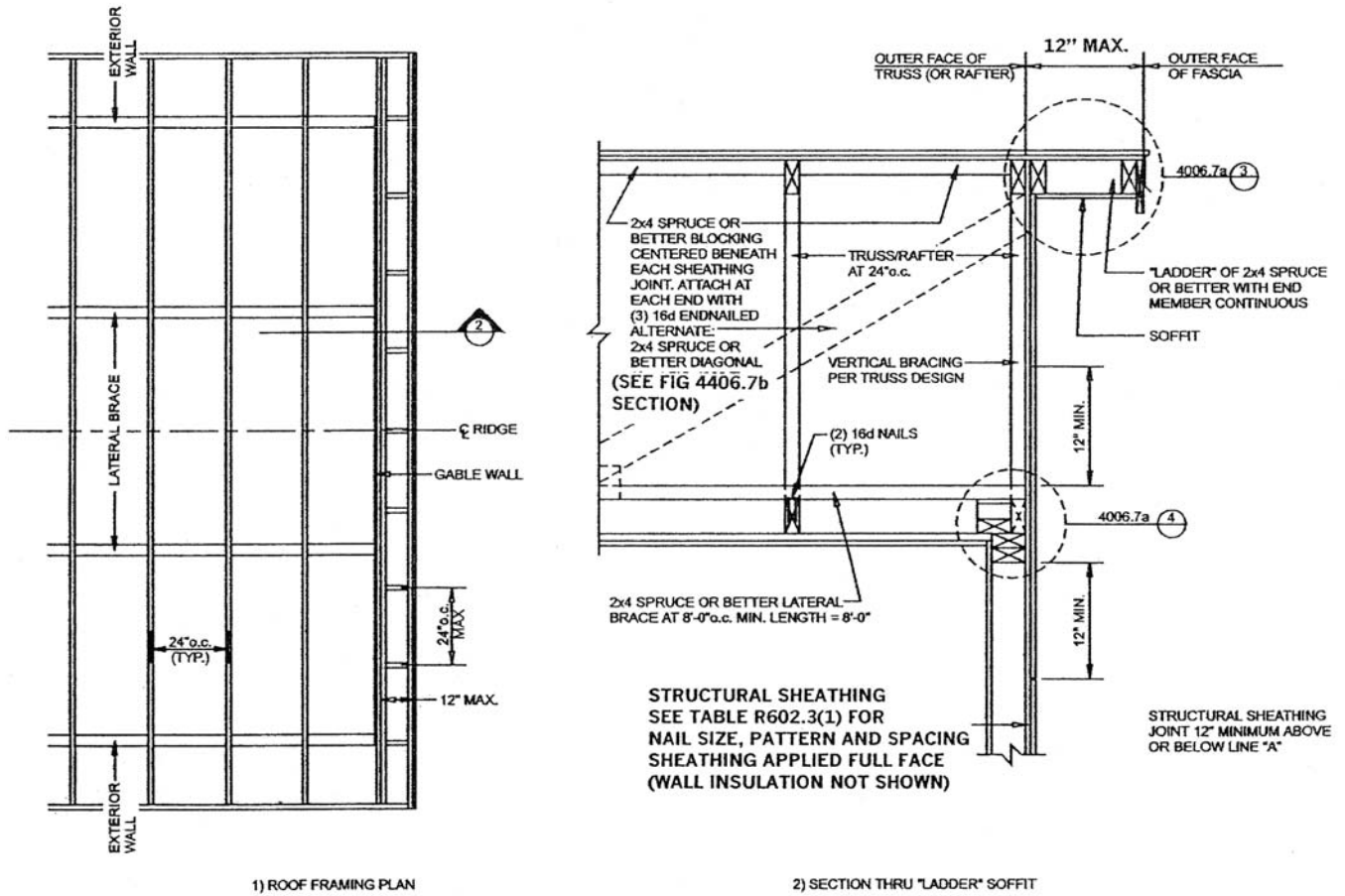

For SI: 1 inch = 25.4 mm.

**FIGURE 4406.7(a)**  
**OVERHANG AT ENDWALLS**

(continued)

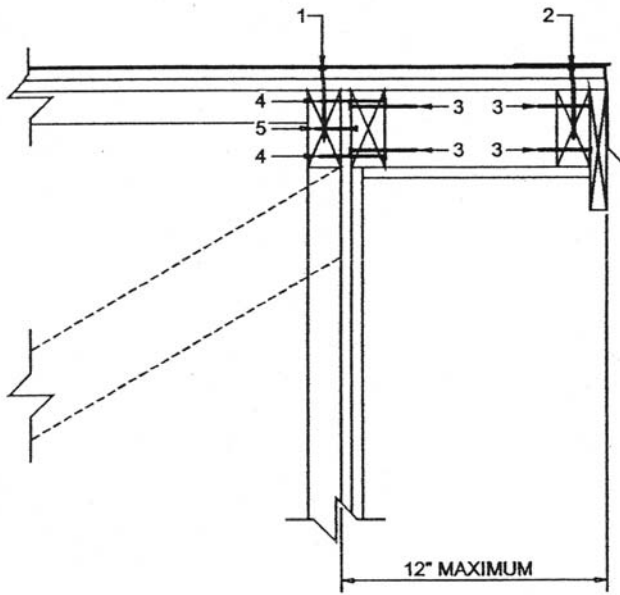

3 4406.7a "LADDER" ATTACHMENT  
NAILING DETAIL AT TOP OF GABLE

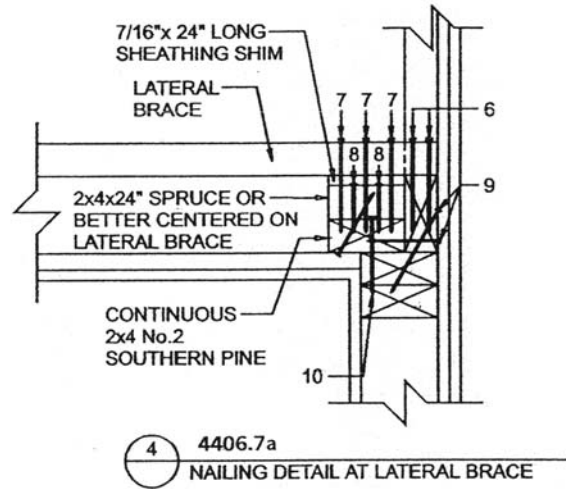

4 4406.7a  
NAILING DETAIL AT LATERAL BRACE

NAIL SCHEDULE			
MARK	No. & SIZE	SPACING	REMARKS
1	8d	4" o.c.	
2	8d	6" o.c.	
3	(2) 16d		EACH SIDE
4	(2) 16d	24" o.c.	
5	8d	6" o.c.	
6	(2) 16d		EACH TRUSS
7	(5) 16d		TYPICAL
8	(6) 16d (* TO 2x4 BELOW)		ALTERNATE: (8) 8d
9	16d	8" o.c.	ALTERNATE TOENAIL & ENDNAIL
10	16d	8" o.c.	

For SI: 1 inch = 25.4 mm.

FIGURE 4406.7(a)—continued  
OVERHANG AT ENDWALLS

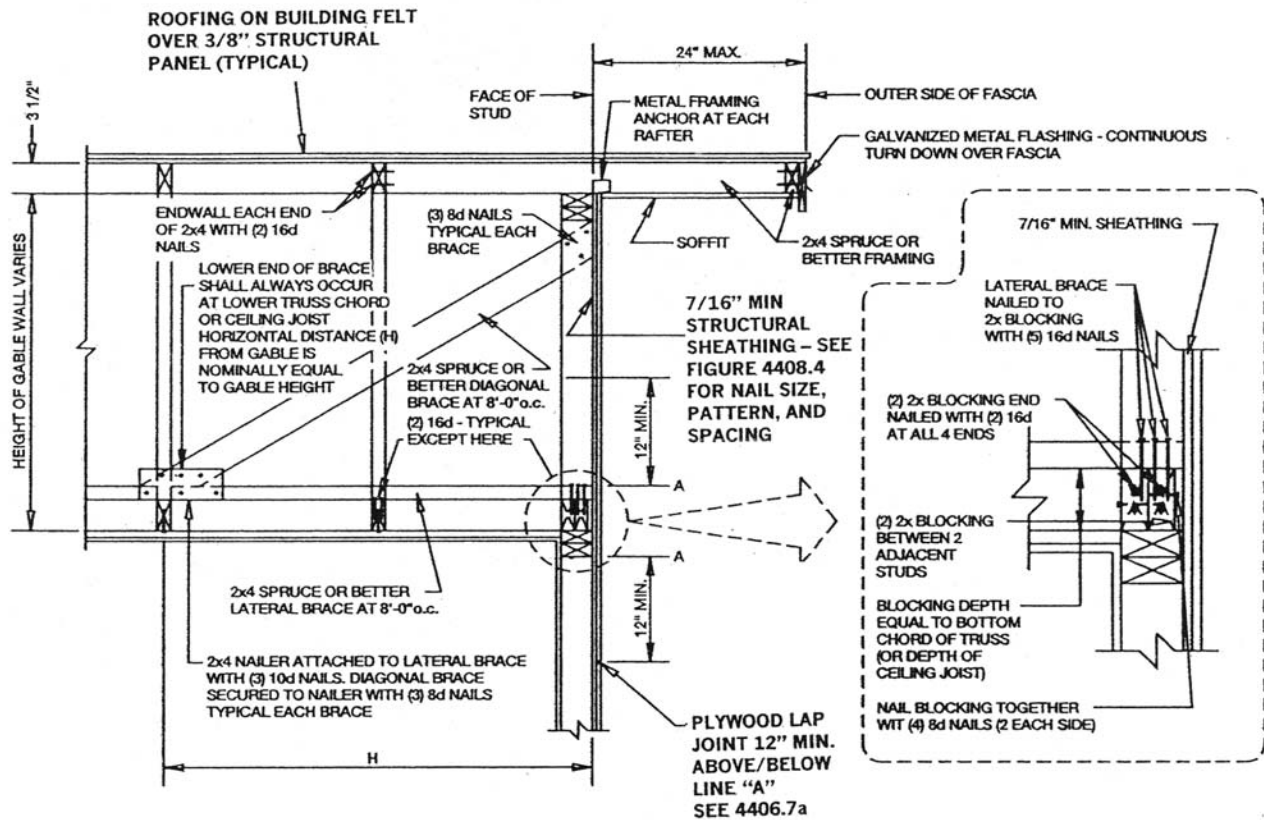

For SI: 1 inch = 25.4 mm.

FIGURE 4406.7b  
GABLE END OVERHANG

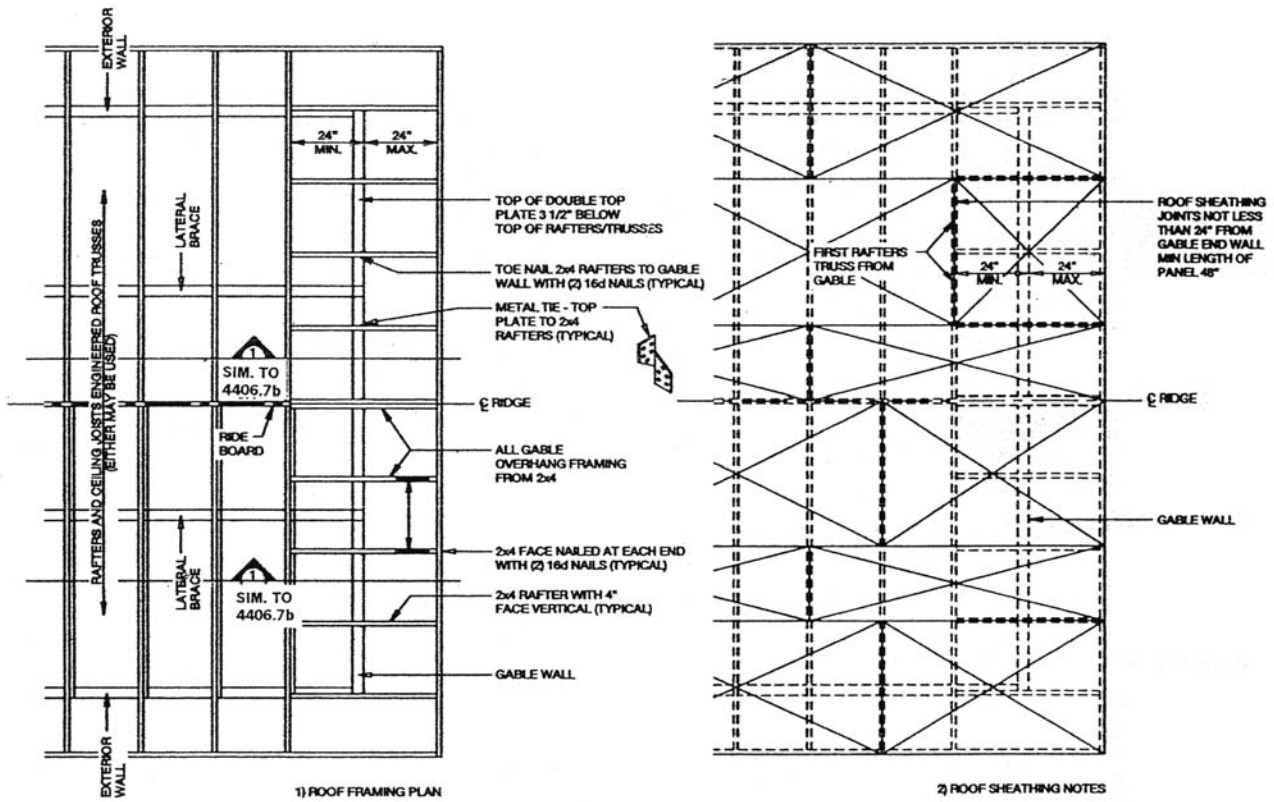

For SI: 1 inch = 25.4 mm.

FIGURE 4406.7(c)  
GABLE OVERHANG

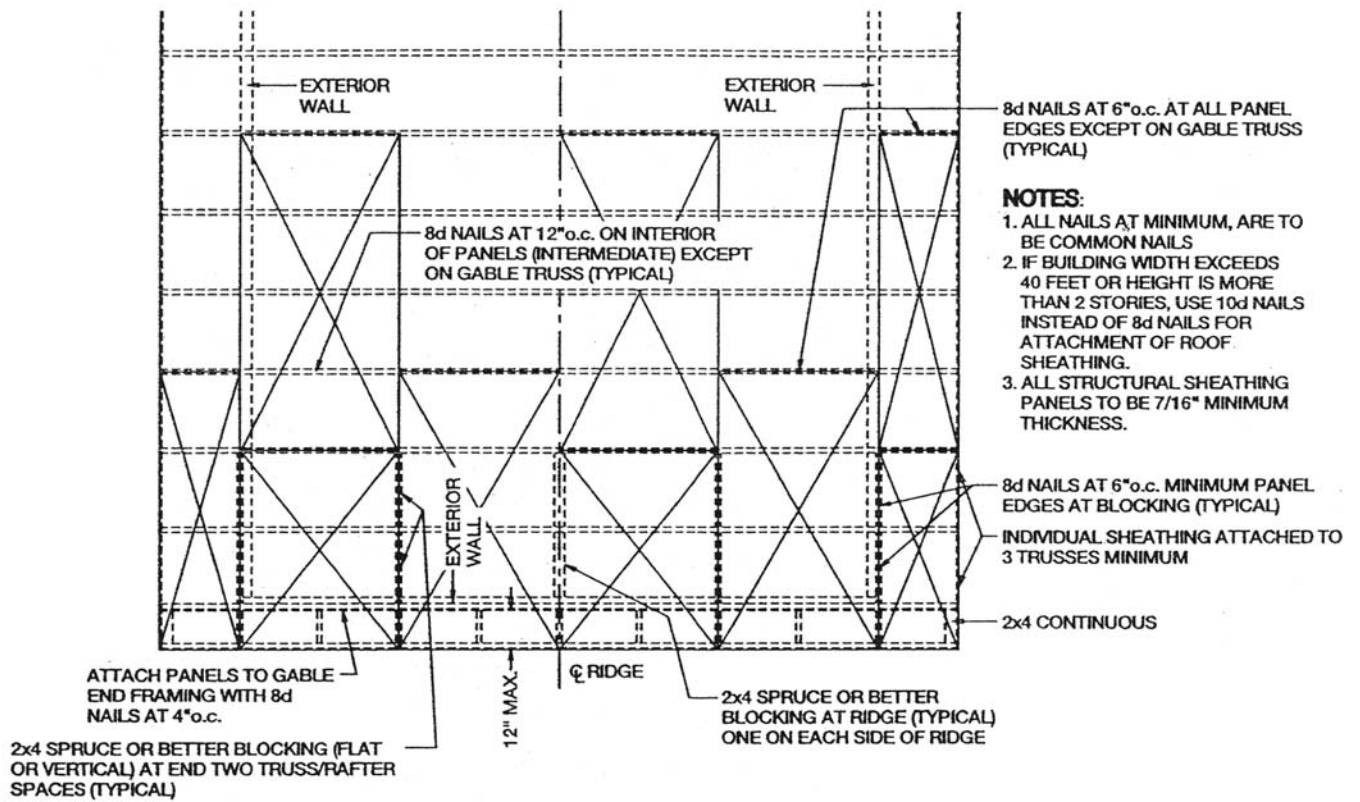

For SI: 1 inch = 25.4 mm.

**FIGURE 4406.8**  
**ROOF SHEATHING ATTACHMENT PLAN**

**SECTION 4407  
MASONRY WALL CONSTRUCTION**

**4407.1 Reinforcement.** Masonry walls subject to wind loads of 120 mph (53 m/s) or greater, as established in Table R301.2(1), shall be constructed in accordance with Tables 4407.1(a) or Table 4407.1(b) or the requirements of Figures 4407.1(a) and 4407.1(b) and this section. In addition, the minimum area of reinforcement shall not be less than 0.002 times the gross cross-sectional area wall, not more than two-thirds of which may be used in either direction. No required vertical reinforcement shall be less than  $\frac{3}{8}$  inch (9.5 mm) in diameter. Principal wall reinforcement shall have a maximum spacing of 4 feet (1219 mm) on center.

**Note:** For 110 mph wind zones, see Figure 606.10(1) and Table 606.8.

**SECTION 4408  
ROOF TIE DOWN**

**4408.1 Roof tie down.** Roof assemblies in the 110 (48 m/s), 120 (53 m/s) and 130 mph (57 m/s) wind zones as established in Table 301.2(1) shall have rafter or truss ties provided in accordance with either Table 4408.2 or the prescriptive requirements of this Section 4408. Anchorage in the 110 mph wind zone shall be continuous from the roof to the foundation wall or pier. Anchorage in the 120 and 130 mph (53 m/s and 57 m/s) wind zones shall be continuous from the roof to the footing (see Section 4404.1).

**4408.2 Considerations.** For trusses, the nailing requirements from Table 4408.2 shall include the nailing requirements for both rafters and ceiling joists. As an alternate to the anchorage requirements of Tables 602.3(1) and 4408.2, the anchorage for roof members may be based on a designed connection taking

**TABLE 4407.1(a)  
H/t LATERAL SUPPORT RATIOS FOR UNREINFORCED EXTERIOR MASONRY WALLS<sup>1,2,4,5</sup>**

Other than Enclosed Buildings <sup>3</sup>		
Design Wind Speed mph		
Wall construction	120	130
Solid mass. units	13	11
Hollow concrete mass. units or mass. bonded hollow walls	9	8
Cavity walls Identical wythes	The H/t ratio shall be 0.70 of the H/t ratio for single-wythe walls. The t-value shall be the sum of the nominal thickness of the individual wythes.	
Cavity walls with wythes of different types or size masonry	The wall shall be designed based on ACI-530 or the H/t ratio may be 0.70 of the H/t ratio of a single-wythe hollow wall. The t-value shall be the sum of the nominal thickness of the individual wythes.	

For SI: 1 inch = 25.4 mm.

1. H = clear height or length between lateral supports.
2. t = nominal wall thickness
3. All masonry units shall be laid in Type M, S or N mortar. Where Type N mortar is used and the wall spans in the vertical direction, the ratios shall be reduced by 10 percent.
4. Design based on partially enclosed building.
5. These values are based on using masonry cement mortar. If nonair-entrained Portland cement/lime mortar is used the values in the table may be increased by 1.25. Larger H/t ratios may be used if the design is done in accordance with ACI-530.

**TABLE 4407.1(b)  
H/t LATERAL SUPPORT RATIOS FOR UNREINFORCED EXTERIOR MASONRY WALLS<sup>1,2,4,5</sup>**

Enclosed Building <sup>3</sup>		
Design Wind Speed, mph		
Wall construction	120	130
Solid mass. units	15	13
Hollow concrete mass. units or mass. bonded hollow walls	10	9
Cavity walls Identical wythes	The H/t ratio shall be 0.70 of the H/t ratio for single-wythe walls. The t value shall be the sum of the nominal thickness of the individual wythes.	
Cavity walls with wythes of different types or size masonry	The wall shall be designed based on ACI-530 or the H/t ratio may be 0.70 of the H/t ratio of a single-wythe hollow wall. The t-value shall be the sum of the nominal thickness of the individual wythes.	

For SI: 1 mile per hour = 0.44 m/s.

1. H = clear height or length between lateral supports.
2. t = nominal wall thickness
3. All masonry units shall be laid in Type M, S or N mortar. Where Type N mortar is used and the wall spans in the vertical direction, the ratios shall be reduced by 10 percent.
4. Enclosed buildings are buildings in which the openings in any wall do not exceed the sum of the percentages of openings in the remaining walls and roof surfaces by 5 percent. Buildings in which the 5 percent limit is exceeded by one wall may still be considered enclosed if the percentage of openings in no other wall exceeds 20 percent.
5. These values are based on using masonry cement mortar. If nonair-entrained Portland cement/lime mortar is used the values in the table may be increased 1.2. Larger H/t ratios may be used if the design is done in accordance with ACI-530.

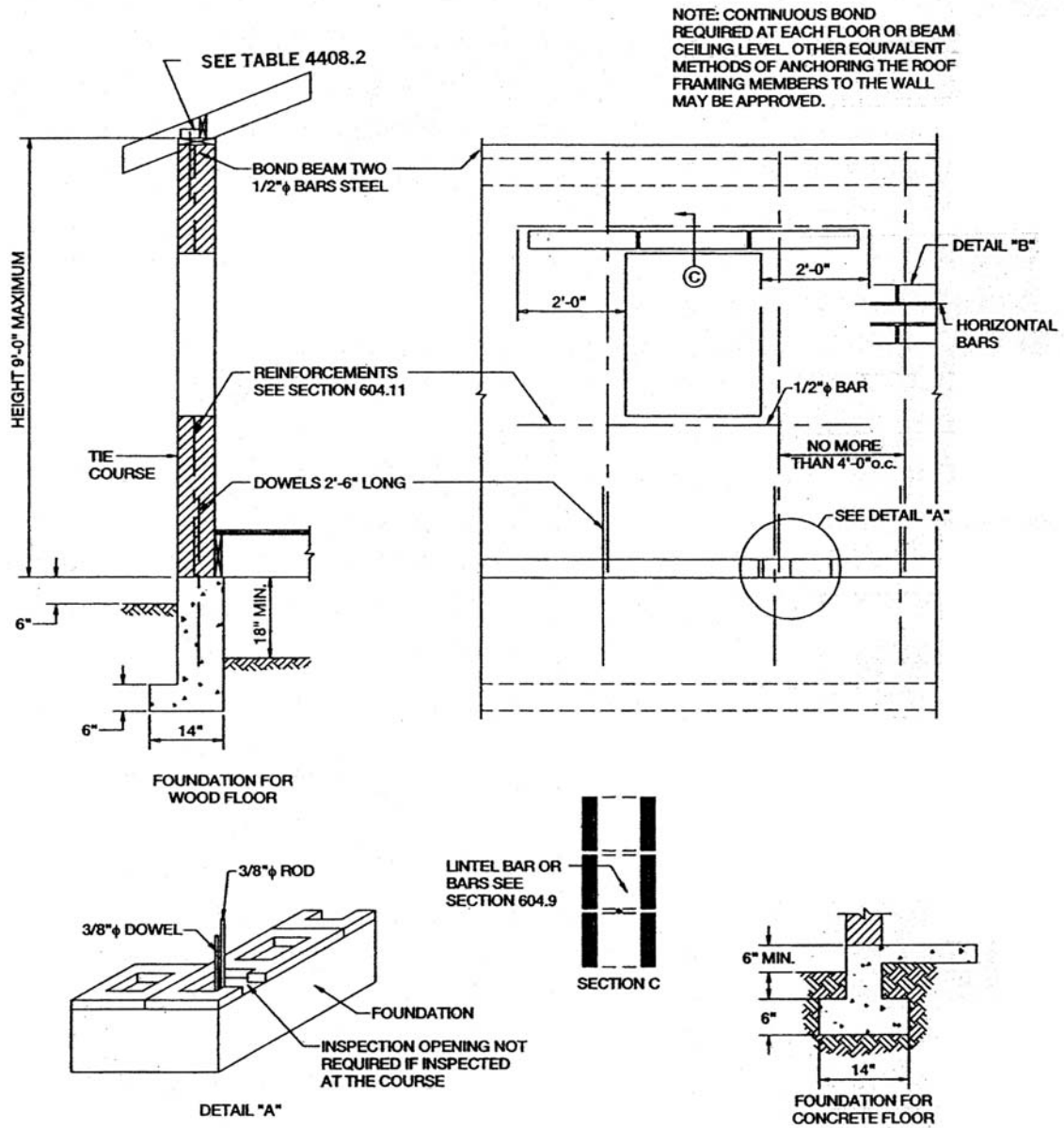

A FULL BED JOINT MUST BE PROVIDED. ALL CELLS CONTAINING VERTICAL BARS ARE TO BE FILLED TO TOP OF WALL. PROVIDE INSPECTION OPENING AS SHOWN ON DETAIL "A". HORIZONTAL BARS ARE TO BE LAID AS SHOWN ON DETAIL "B". LINTEL BARS ARE TO BE LAID AS SHOWN ON SECTION "C".

For SI: 1 inch = 25.4 mm, 1 foot = 304.8, 1 psf = 0.0479 kN/m<sup>2</sup>, 1 mile per hour = 0.44 m/s.

FIGURE 4407.1(a)  
 REQUIREMENTS FOR REINFORCED GROUTED MASONRY CONSTRUCTION  
 WHERE WIND ZONES ARE 120 MPH OR GREATER

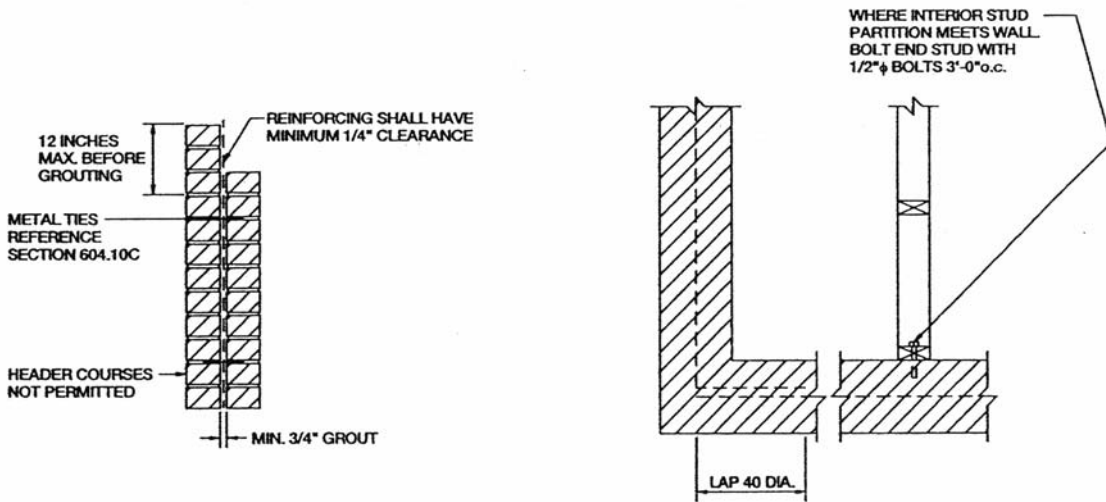
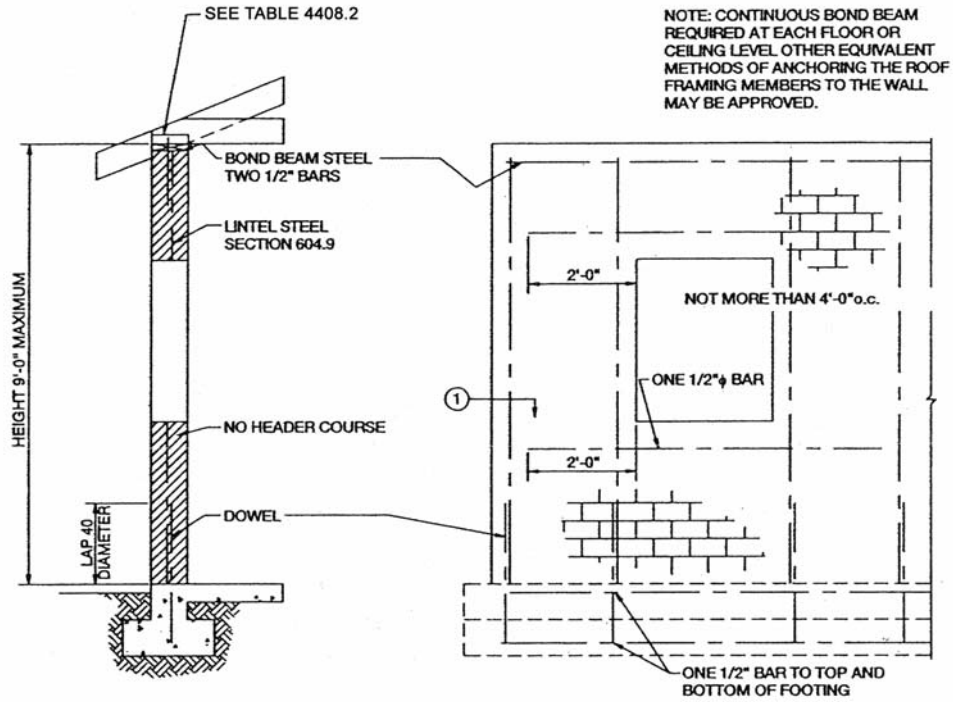

For SI: 1 inch = 24.5 mm, 1 foot = 304.8, 1 psf = 0.0479 kN/m<sup>2</sup>, 1 mile per hour = 0.44 m/s.

**FIGURE 4407.1(b)**  
**REQUIREMENTS FOR REINFORCED HOLLOW-UNIT MASONRY CONSTRUCTION**  
**WHERE WIND ZONES ARE 120 MPH OR GREATER**



into account all horizontal and vertical forces. Forces for alternate anchorage design may result from wind uplift, wind lateral on roof, wind lateral on walls to be transferred to the top plate of the wall, roof/ceiling loads, and other loads depending on the specific building design. If roof members align with the studs, the connection may be made from the roof member directly to the studs. If the connection is from the roof member to the top plate, a double top plate is required and both connections must meet the requirements of Table 4408.2. Where ceiling joists are not parallel with and connect to the roof members, the anchorage requirements for each roof member shall be increased by 110 pounds (45 kg). Hip end walls and hip rafters shall be anchored in accordance with this section.

**TABLE 4408.2  
ROOF TIE DOWN REQUIREMENTS ALONG EXTERIOR WALLS(plf)**

Wind Speed (mph)	Structure Width (ft)	
	24	36
110	240	345
120	330	470
130	430	615

For SI: 1 foot = 304.8 mm, 1 mile per hour = 0.44 m/s.

1. Alternate to the requirements of this table or roof not covered by this table shall be designed in accordance with the North Carolina State Building Code, Volume 1 – General Construction or SSTD-10, “Standard for Hurricane Resistant Residential Construction.”
2. See Section 4505 for material requirements in Coastal High Hazard Areas and Ocean Hazard Areas and Ocean Hazard Areas.
3. Roof slope 2:12 to 12:12.
4. The uplift load requirements may be interpolated for intermediate structure widths.

**4408.3 Anchorage from roof to wall.** One and one-half inch (38 mm) by 18 gage fabricated metal ties at 24 inches (610 mm) o.c. with five 8d nails at each end may be used to resist the uplift loads from the roof to the double top plate. Install one tie at each end of each rafter or truss member in 110 mph (48 m/s) and two ties at each end of each rafter or truss member in 120 mph (53 m/s) and 130 mph (57 m/s) wind zones.

**4408.4 Anchorage using wood structural panels.** Wood structural panel sheathing may be used to resist both lateral load and uplift simultaneously. Panels shall be installed as follows:

1. Panels may be installed with face grain parallel or perpendicular to studs.
2. Panels shall be  $\frac{3}{8}$  inch (9 mm) minimum thickness.
3. Nail spacing shall be 8d at 6 inches (152 mm) o.c. along vertical edges of panel and 12 inches (305 mm) at intermediate vertical framing.
4. Horizontal nail spacing at double row of 8d staggered at 3 inches (76 mm) o.c.
5. Panel shall extend 12 inches (305 mm) beyond construction joints and shall overlap girders their full depth.
6. Panel attachment to framing shall be as illustrated in Figure 4408.4.
7. Blocking shall be required at all joints if sheathing is used to resist uplift.

**TABLE 4408.4  
UPLIFT CAPACITY OF WOOD STRUCTURAL OF WOOD STRUCTURAL PANEL SHEATHING USED TO RESIST BOTH LATERAL LOAD AND UPLIFT<sup>1</sup>**

Vertical Nail Spacing	8d @ 6" Edge and 12" Intermediate		
Alternate Nail Spacing @ Top and Bottom Edges	6"	4"	3"
Uplift Capacity (PLF) Nails – Double Row	240	474	710

For SI: 1 inch = 25.4 mm.

1. Tabulated values are for Spruce-Pine-Fir framing. For Southern Pine framing, the uplift values listed may be divided by 0.82.

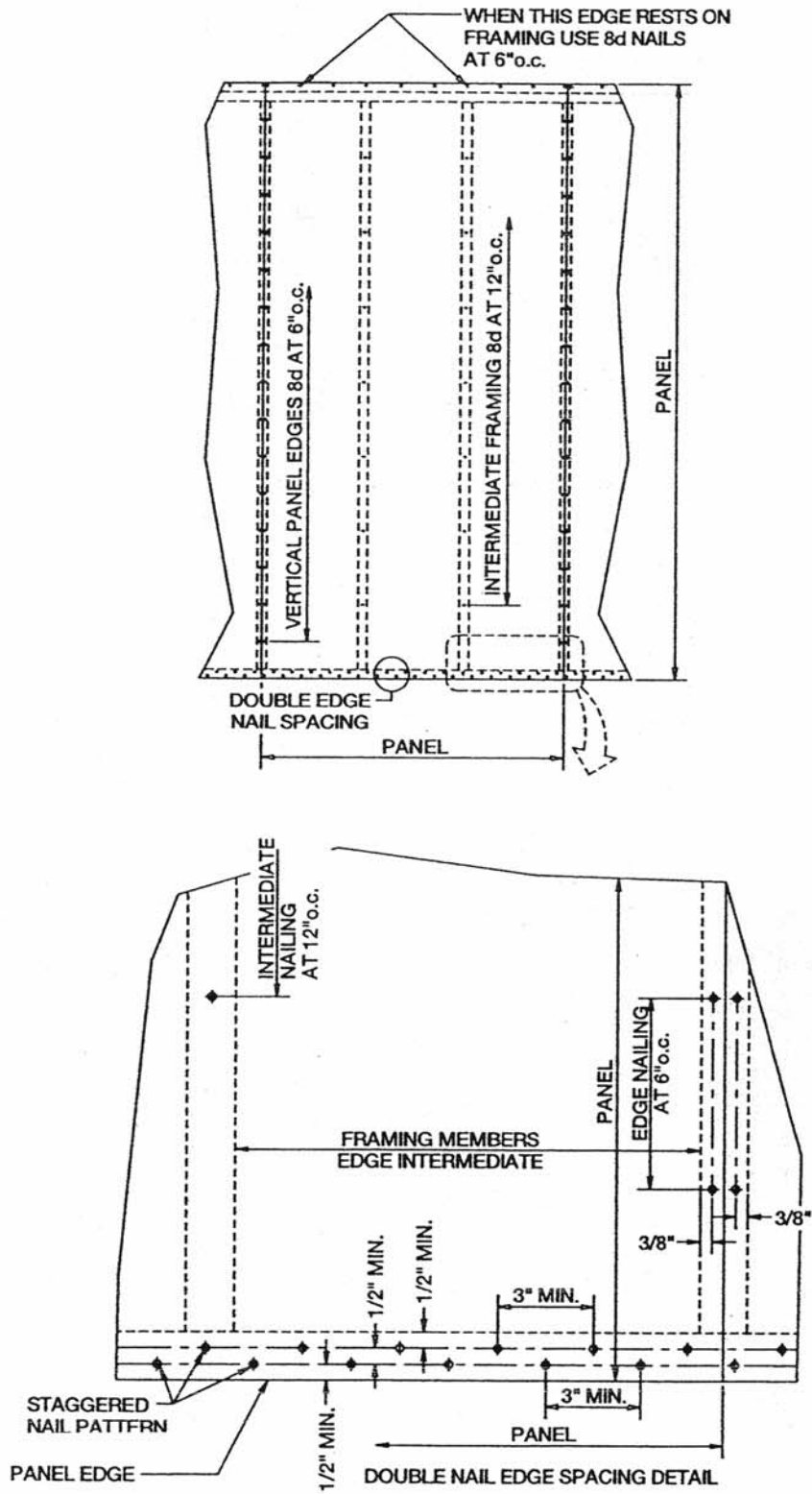

For SI: 1 inch = 25.4 mm

FIGURE 4408.4  
 PANEL ATTACHMENT TO COUNTER UPLIFT HORIZONTAL OR VERTICAL